

CAD FILE:

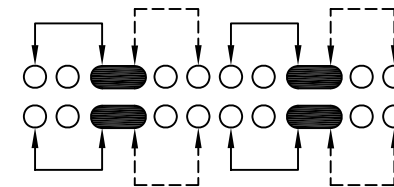

SCHEMATIC (NON-SPECIFIED)

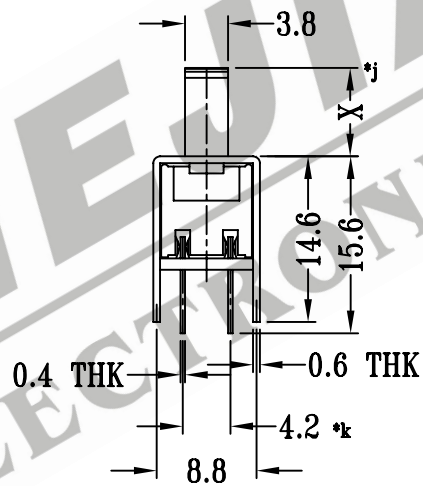
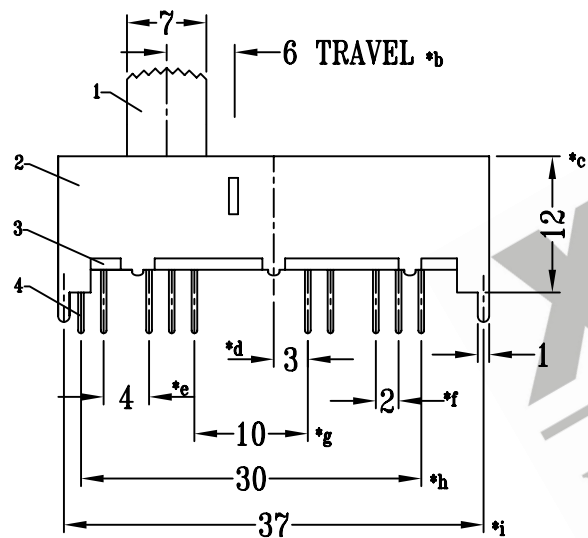
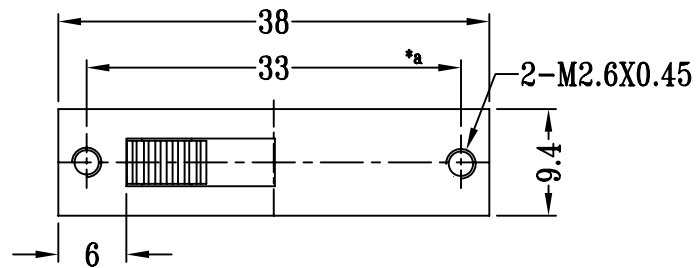
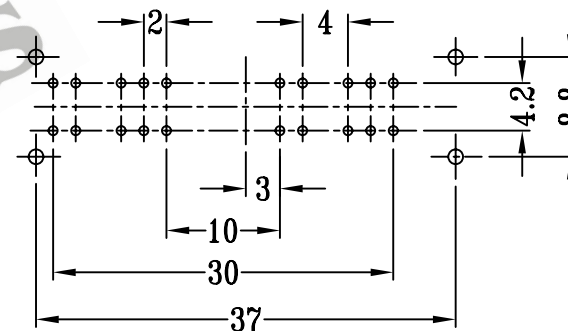

P.C.B LAYOUT

注:带"*"表示关键尺寸(11个)

NO.	PART NAME	MATERIAL	Q'TY	FINISHING	TOLERANCE UNLESS SPECIFIED	SHENZHEN XIEJIA ELECTRONICS CO.,LTD.				
8						ISSUE	DATE	DESCRIPTIONS		APPD.
7	CONTACT (CLIP)	PBS STRIP	4	Ag PLATED	WITHIN: 1.5±0.1mm					
6	SPRING	STEEL STRIP	1	TEMPER	OVER : 1.5±0.2mm	MODEL: SS-42L02		SCALE: 3:2	DWN. ZHOUYU	2005-9-12
5	STEEL BALL	STEEL	2	NATURAL		ALL MATERIALS MUST BE COMPLIANT TO ROHS		CHK'D	FANGYING	2005-9-12
4	TERMINAL	BRASS STRIP	20	Ag PLATED OVER Ni PLATED				APPD.	KANGXINAN	2005-9-12
3	TERMINAL BASE	PHENOLIC RESIN	1	NATURAL						
2	FRAME	STEEL STRIP	1	Ni PLATED						
1	KNOB	POM	1	BLACK						